

Technical Information

Installation, Operation, and Maintenance Manual

VWR 89237-564 Zero Air Generator

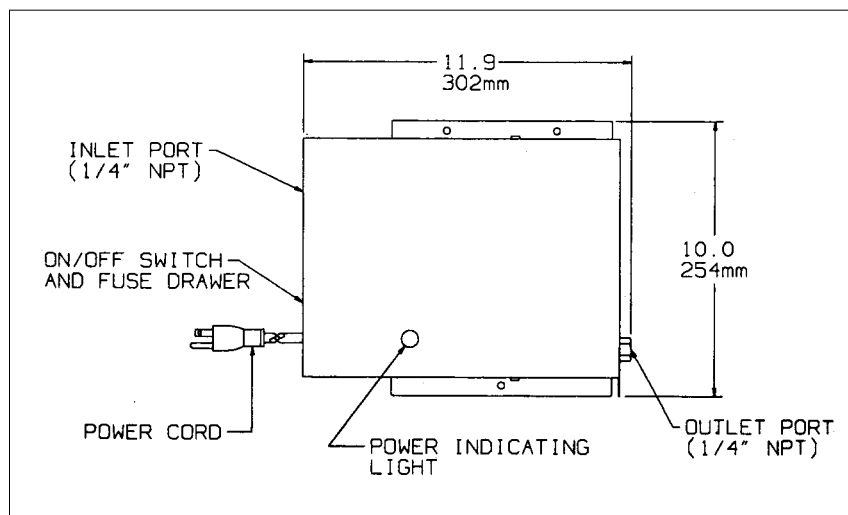

Figure 1 - VWR Zero Air Generator

These instructions must be thoroughly read and understood before installing and operating this product. Failure to operate this product in accordance with these instructions could present a safety hazard to the user and will void the safety certification of the product. Modification of the unit will result in voiding the warranty. If you have any questions or concerns, please call the VWR Technical Services Department at 800-932-5000, 8AM to 5PM Eastern Time (North America only). For other locations, contact your local representative.

Save all product packaging materials for future use.

General Description

The VWR Zero Air Generator is an engineered system which will replace inconvenient high pressure gas cylinders as a source of hydrocarbon-free air. The 89237-564 will purify on-site compressed air to a total hydrocarbon concentration of less than 0.1 ppm (measured as methane). The Zero Air Generator may be used to generate fuel air for Flame Ionization Detectors (FID's) or for a zero reference for any instruments which measure hydrocarbon concentration. The 89237-564 is capable of producing up to 1000 cc/min of zero grade air and will serve up to three FID's.

Regulatory Compliance

These products are certified to the electrical safety requirements as specified by the IEC, CSA, and UL standards. These units bear both the CSA and CUL markings on the product label. Product supplied to Europe carries the CE mark (220/230/240 VAC units only). The product meets EMC compliance.

Engineered System

The VWR Zero Air Generator includes all of the components necessary to purify compressed air into zero-grade hydrocarbon-free air. The generator comprises three primary functional groups: prefiltration, hydrocarbon removal, and final filtration (see Flow Schematic, Figure 2).

Prefiltration

A high efficiency coalescing filter has been incorporated into the design of the VWR Zero Air Generator as a prefilter to remove oil, water, and particulate contamination from the incoming compressed air supply. The prefilter assembly is equipped with a manual drain to eliminate any liquids which have accumulated within the filter housing.

Hydrocarbon Removal

The catalyst module is a stainless steel housing filled with catalyst and assembled with a heater. The catalyst module oxidizes hydrocarbons from the compressed air supply into carbon dioxide and water. The module is sized to deliver 1000 cc/min. of zero-grade hydrocarbon-free air to the instrumentation downstream.

Final Filtration

The final filter on the VWR Zero Air Generator is a high efficiency sintered metal filter which removes particulate contamination to 0.5 micron. This final filter ensures that the outlet air from the VWR Zero Air Generator is particle-free.

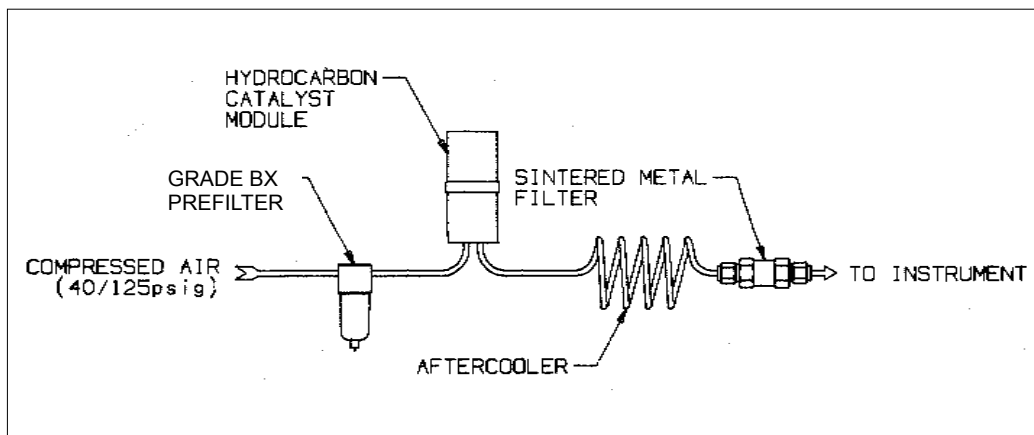

Figure 2 - Flow Schematic

Installation

All installation, operation, and maintenance activities for the VWR Zero Air Generator should be performed by suitable personnel using reasonable care.

General

The VWR Zero Air Generator is designed to mount on the wall or rest on the benchtop. The inlet and outlet ports are 1/4" female NPT. The inlet port is located on the left side of the generator, at the inlet to the prefilter (see Figure 5). The outlet port is also 1/4" female NPT, and it is located on the right side of the generator (see Figure 5). Male 1/4" NPT pipe fittings rated for 125 psig (8.5 barg) line pressure should be used to connect to the generator.

A shut-off valve and a pressure regulator should be installed directly upstream from the VWR Zero Air Generator. The shut-off valve isolates the unit from the air line for maintenance and troubleshooting tasks. The pressure regulator controls the inlet air pressure and should be set to maintain a constant pressure between 40 psig and 125 psig (2.7 barg and 8.5 barg). Maintaining a constant inlet air pressure will minimize any system pressure fluctuations which may affect the purity of the zero grade air generated. VWR offers a pressure regulator, complete with a pressure gauge, as an accessory (P/N 72-130-V883).

Location

The 89237-564 should be located in close proximity to the compressed air supply, the electrical power supply, and the downstream equipment which it supplies. There is no limit to the distance between the generator and the point of use as long as tubing size, cleanliness, and pressure drop are taken into consideration. The generator should be located indoors, protected from severe weather conditions. The installation location should also be free from excessive ambient dust or dirt. **Do not install the generator outdoors.** The ambient temperature of the air surrounding the generator must be between 60°F and 100°F (16°C and 40°C) to ensure optimal operation of the unit.

Mounting

If mounting the unit on a wall, drill mounting holes into the wall using the mounting dimensions shown in Figure 3. (Mount the generator in a vertical position only. Mounting or placing the generator in any other orientation will compromise the effectiveness of the hydrocarbon removal, and will void the warranty.) Next, secure the 89237-564 to the wall using mounting hardware which is adequately sized to support the weight of the unit (7 lbs./3 kg) in its mounted position. All mounting should be in compliance with National Electrical Code (NEC) and local building code guidelines. Allow 6" (15 cm) clearance around sides of generator for adequate ventilation.

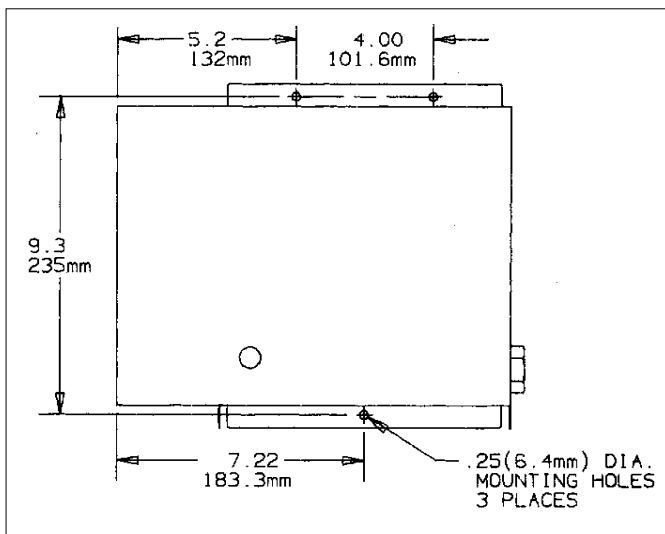

Figure 3 - Mounting Dimensions

Utilities

Compressed Air - The VWR Zero Air Generator requires a source of clean, dry compressed air for optimal operation. The compressed air should be as close to instrument quality as possible, and supplied at a pressure and flow rate above that required at the point of use. The temperature and/or dewpoint of the supply air should be at room temperature (or lower), and it should be relatively free from compressor oil, hydrocarbons, and particulate matter. Contamination of the catalyst bed may occur if it is exposed to certain compounds (see warning, below). If the compressed air supply for the 75-83 has excess water, oil, or particulate contamination, install extra prefiltration upstream from the unit (see Recommended Accessories section, page 4).



Chlorinated hydrocarbon compounds and chlorofluorocarbons (or freons) will permanently contaminate the hydrocarbon catalyst module in the 89237-564 Zero Air Generator. Extreme care should be taken when specifying an air supply for the generator to ensure that these compounds are not present in the air supply nor likely to get into the compressor providing air to the generator.

The hydrocarbon catalyst module can also be contaminated by high concentrations of lead, sulfur, or phosphorous compounds, heavy metals, and long chain polymers. Care should be taken to avoid introducing these compounds into the VWR Zero Air Generator. Specifically, assure that none of these compounds are stored near the inlet to the compressor supplying the system with compressed air. The intake for the compressor should be vented to the outdoors.

Connect the compressed air supply to the 1/4" NPT (female) inlet port on the left side of the generator (see Figure 1).

Power - The electrical requirement for the VWR 89237-564 Zero Air Generator is 120 VAC (0.5 amps) or 230 VAC (0.2 amps), 50/60 Hz (depending on the model purchased). (**Note:** Main supply voltage must be within 10% of the nominal rated voltage for the generator.)

To connect the generator to the power supply, simply plug the female end of the electrical cord into the receptacle on the left side of the generator, and plug the opposite end into a nearby three-pronged earthed receptacle. (**Note:** Do not use a Ground Fault Circuit Interrupter (GFCI) in conjunction with generator.)

Utilities (Continued)

Piping Components - The inlet and outlet ports for the VWR Zero Air Generator are 1/4" NPT (female) and are located on the sides of the unit. Inlet tubing and fittings should be clean and rated for 125 psig (8.5 barg), minimally. The tubing and fittings used downstream from the 89237-564 should be clean stainless steel or pre-cleaned refrigeration-grade copper (1/4" o.d. x .030" wall) and rated for 125 psig (8.5 barg), minimally. **Do not use plastic tubing downstream from the generator.** Outgassing from the plastic may contaminate the zero-grade gas. Use PTFE tape on all inlet and outlet NPT fittings. (Thread sealing compounds may contaminate the process stream.)

If pre-cleaned copper tubing is unavailable, standard copper tubing may be cleaned by the customer. First, connect the tubing to a supply of clean inert gas (N₂, He). Next, initiate the gas flow through the tubing (5-10 min.). Finally, heat the tubing with a propane torch, moving the flame at a rate of approximately 1/2 in./sec. in the direction of flow. This procedure removes waxes and oils used in the manufacture of the tubing.

Note: The use of plastic piping components or unclean copper or stainless steel piping components will result in the 89237-564 failing to meet purity specifications.

Connect downstream delivery lines to the 1/4" female NPT port on the right side of the generator.

Flow Controller - A flow control device should be installed downstream from the generator if one is not integral to the instrumentation used. If the flow capacity of the generator is exceeded, the 89237-564 will fail to meet its hydrocarbon specification (0.1 ppm).

Recommended Accessories

Recommended Accessories

W-405-4032-000 Pressure Regulator - To control the incoming air pressure to the 89237-564, VWR recommends the use of a pressure regulator. The **W-405-4032-000** is a pressure regulator with 1/8" tube ports, assembled with a 0-130 psig (0-9.3 barg) pressure gauge. For more information, please request the Analytical Gas Systems Product Catalog.

W-FM7583 Flow Controller - To control the flow rate of air through the zero air generator, VWR recommends the use of a high purity flow controller. The **W-FM7583 Flow Controller** is a flow meter and controller with 1/8" or 1/4" compression fitting ports. For more information, please request the Analytical Gas Systems Product Catalog.

Prefiltration - If instrument quality compressed air is desired, or if excess water collects in the 89237-564 prefilter, an extra stage of prefiltration should be installed on the compressed air supply line, upstream from the 89237-564.

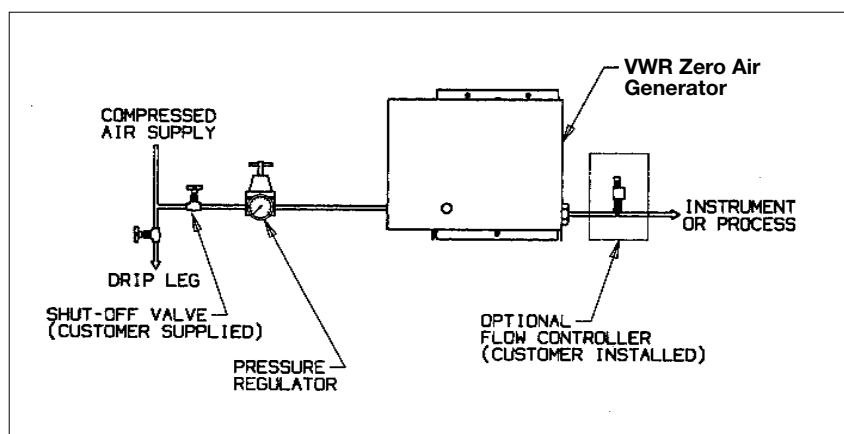

Figure 4 - Recommended Installation

Operation

Startup

Open the inlet air supply valve (customer supplied, see Installation section) and adjust the inlet pressure to be between 40 psig and 125 psig (2.7 barg and 8.5 barg) using a (customer installed) pressure regulator. Adjust the outlet flow (using a customer installed flow controller) to the rated flow for the unit. Turn the generator on using the power switch on the side panel. When power is brought to the unit, the catalyst module will begin to heat up. The VWR Zero Air Generator requires approximately 45 minutes to warm up and achieve hydrocarbon removal to 0.1 ppm.

Operation

After the generator has warmed up, adjust the flow to meet the requirements of the application. **Do not exceed the rated flow of the unit.** If the rated flow of the 89237-564 is exceeded, the life and performance of the unit will be adversely affected and the warranty will be void. The outlet air will contain hydrocarbons in excess of 0.1ppm.

The VWR Zero Air Generator is designed to operate continuously, 24 hours per day, as long as the electricity and compressed air supply are not interrupted.

Shutdown

VWR recommends allowing the Zero Air Generator to run continuously, shutting the unit down only when compressed air is not available or when the generator requires servicing. The continuous operation of the generator maximizes the life of the catalyst heater. To shut down the VWR Zero Air Generator, turn the power switch to the off position. Maintain the compressed air flow through the unit for approximately 10 minutes to improve heat dissipation. After 10 minutes, turn off the compressed air supply to the generator.



Warning: Do not supply electrical power to the generator until the compressed air flow rate through the unit is at the rated capacity (see Specifications section, page 7). Operating the generator for extended periods of time without compressed air will damage the heater within the catalyst module and void the warranty.

Maintenance

All maintenance procedures should be performed by suitable personnel using reasonable care.

General

The primary maintenance tasks required by the VWR Zero Air Generator are: changing the prefilter cartridge (annually), changing the sintered metal filter assembly (annually), and replacing the catalyst module (2 years). Each of these components is readily accessible by removing the front panel of the generator. It is not necessary to remove the unit from its mounted position to perform maintenance on the generator. A summary of the replacement part numbers and recommended service frequency is shown at the end of this Maintenance section. See Figure 5 for the locations of the prefilter, final filter, and catalyst module.

Additional coalescing prefilter cartridges and final filter cartridges for the VWR Zero Air Generator may be ordered through your local representative. For convenience, the replacement prefilter cartridge and final sintered metal filter have been assembled into a maintenance kit (P/N MK7583).



If necessary, the 89237-564 may be wiped clean with a dry cloth on an as needed basis. **Do not use water, aerosols, or other cleaning agents to clean the unit.** Use of any liquid detergent to clean the generator could present an electrical hazard.



Before servicing the VWR Zero Air Generator, isolate the unit from the compressed air and electrical supplies, depressurize the prefilter, and turn the unit off.

Prefilter Cartridge Maintenance

The only tool required to change the prefilter cartridge is a Phillips head screwdriver. Use the screwdriver to remove the generator cover. The Grade BX prefilter will be accessible from the front of the generator, after the generator cover is removed. The filter cartridge inside the housing should be changed on an annual basis to maintain efficient operation of the system. **Prior to changing the cartridge, remove any residual pressure within the housing by depressing the manual drain valve at the base of the filter bowl.** Remove the filter cartridge housed in this filter assembly by unscrewing the filter bowl from the filter head and unscrewing the element retainer disc from the tie rod. Insert the new filter cartridge (P/N 050-05-BX) and re-assemble the filter housing in reverse order.

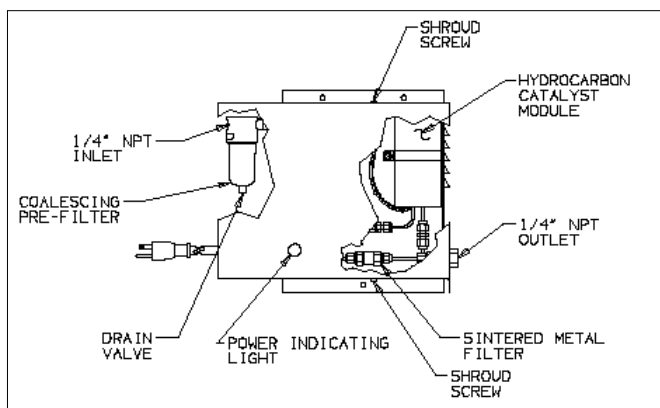

Figure 5 - Cutaway View

Final Filter Maintenance

The final sintered metal filter assembly in the VWR Zero Air Generator is easily replaced using two 7/16" wrenches (or two adjustable wrenches). To remove the spent filter, simply use the wrenches (one as an anchor) to disconnect the filter assembly from the tubing. Replace the spent filter with a new filter (P/N A01-0185) and re-assemble. Dispose of the spent filter assembly according to local regulations.

Catalyst Module Replacement

The catalyst module (P/N 75394) in the VWR Zero Air Generator should be changed every two years to maintain the hydrocarbon removal specification for the unit.

The tools required to change the catalyst module are: a Phillips head screwdriver, a flat head screwdriver, and two 7/16" open end wrenches (or two adjustable wrenches). The procedure for replacing the catalyst module is as follows (see Figure 5 for component locations):

- 1 Switch off the power to the unit and unplug the generator from the power receptacle. Allow the compressed air to continue to flow through the 75-83 to improve heat dissipation during cooling. **Allow the generator to cool for at least 2 hours.**
- 2 Close the (customer installed) inlet air valve and remove the cover from the generator. The cover is held on by 2 Phillips head screws, one on the top, and one on the bottom of the cover. Bleed any residual pressure from the system by depressurizing the prefilter.
- 3 Disconnect the electrical fitting to the catalyst module at the connector.
- 4 Using the two wrenches (one as an anchor), disconnect the module inlet and outlet fittings at the elbow. **Leave elbow and one fitting attached to the module at the inlet and outlet.**
- 5 Remove the clamp screw to release the catalyst module from the generator. The insulation blanket is removed with the module, elbows, and fittings. Replace the spent module with the replacement module by reversing the removal procedure.
- 6 Pressurize the system and check thoroughly for leaks using a leak detecting or solution.
- 7 Replace generator cover and commence operation as detailed in the Startup section of this manual.

Fuse Replacement

Occasionally, one or both of the fuses in the 89237-564 may burn out. The fuses are located in the power receptacle on the left had side of the generator. **Before servicing the fuses, turn the generator off and disconnect the power cord from both the power supply and the generator power receptacle.**



To access the fuses, use a small screwdriver to remove the fuse holder located in the power receptacle of the generator. In the 89237-564, both the phase and neutral are fused separately. As a result of this configuration, both fuses should be checked any time fuse replacement is warranted. Replace either one or both fuses as necessary and re-assemble. **To maintain the safety and performance integrity of the product, use only fuses of the size and type detailed in the specifications section of this bulletin.**

Ordering Information

Replacement Parts	P/N	Change Frequency	
Maintenance Kit (prefilter, sintered metal filter)		89237-568	1 year
Final Filter		A01-0185	1 year
Replacement Catalyst Module*	120 V Model: 220 V Model:	75394 75394	2 years 2 years
Prefilter		050-05-BX	1 year
Replacement Fuses	120 V Model: 220 V Model:	13219 A03-0128	as needed as needed

* For 220 version Zero Air Generators with serial number 75832201130D or earlier, the catalyst module Model Number is 75394-220

System Specifications

		89237-564
CSA Certification Standard (1)		CAN/CSA C22.2 No. 1010.1-92
IEC Certification Standard		IEC 1010-1/EN61010-1
IEC 1010 Installation Category		Category II
IEC 1010 Pollution Degree		Degree 2
UL Certification Standard		UL3101-1/UL61010A-1
EMC Standards		CISPR11/EN55011/EN50082-1
Maximum Flow Rate		1000 cc/min.
Total Hydrocarbon Concentration		<0.1 ppm
Total Carbon Monoxide (CO) Concentration		<1.0 ppm
Outlet Air Temperature		ambient +20°F (+11°C)
Min/Max Ambient Temperature		60°F/100°F (16°C/40°C)
Minimum/Maximum Inlet Pressure		40/125 psig (2.7 barg/8.5 barg)
Maximum Relative Humidity		80%
Altitude		2000 m
Maximum Inlet Hydrocarbon Content		100 ppm
Pressure Drop at Max. Flow Rate		<5 psid (0.3 bar)
Startup Time		45 min.
Electrical Requirements (2)		120 VAC, 230 VAC, 50/60 Hz
Physical Dimensions		12"w x 10"h x 3"d (30cm x 25cm x 8cm)
Shipping Weight		7 lbs. (3 kg)
Fuses	120 V model:	5 x 22 mm, Type T, 250 V, 0.5 amps
	220 V model:	5 x 22 mm, Type T, 250 V, 0.315 amps

1 220 VAC models have CE mark for European distribution.

2 Main supply line voltage must be within 10% of nominal rated voltage for the generator.

Optional Accessories

Accessory	P/N
Pressure Regulator (0-130 psig) (0-8.8 barg)	W-405-4032-000
Installation Kit	82031-484
Extra Prefilter Assembly	A914-DX
Flow Meter	W-FM7583

Don't Forget To:

- 1 Complete and mail your registration card.
- 2 Keep your product certification in a safe place.
- 3 Call the VWR Technical Services Department at 800-932-5000, 8AM to 5PM Eastern Time with any questions. For other locations, please contact your local representative.

Serial Numbers

The serial number label for the unit is located behind the filter access panel, near the power receptacle. For your own records, and in case service is required, please record the following:

DATE IN SERVICE _____ SERIAL NO. _____

Please have the serial number available when calling for assistance.



1.800.932.5000 | vwr.com

Prices and product details are current when published; subject to change without notice. | Certain products may be limited by federal, state, provincial, or local regulations. | VWR makes no claims or warranties concerning sustainable/green products. Any claims concerning sustainable/green products are the sole claims of the manufacturer and not those of VWR International, LLC. All prices are in US dollars unless otherwise noted. Offers valid in US and Canada, void where prohibited by law or company policy, while supplies last. | VWR, the VWR logo and variations on the foregoing are registered (®) or unregistered trademarks and service marks, of VWR International, LLC and its related companies. All other marks referenced are registered by their respective owner(s). | Visit vwr.com to view our privacy policy, trademark owners and additional disclaimers. ©2013 VWR International, LLC. All rights reserved.

CELL: ZAG

