

VWR®

vwr™
part of avantor

Gas Regulators and accessories

01. SAFE, ACCURATE, AND SENSITIVE
PRESSURE CONTROL

02. SINGLE-STAGE AND TWO-STAGE
REGULATORS TO SUIT YOUR NEEDS



Gas pressure regulator selection

Gases can be supplied in compressed gas high-pressure cylinders, liquid low-pressure cylinders, or from low-pressure pipeline supply. The pressure from the supply source must be reduced to the desired working pressure for the application. To accomplish this, a pressure-reducing valve commonly referred to as a regulator needs to be selected.

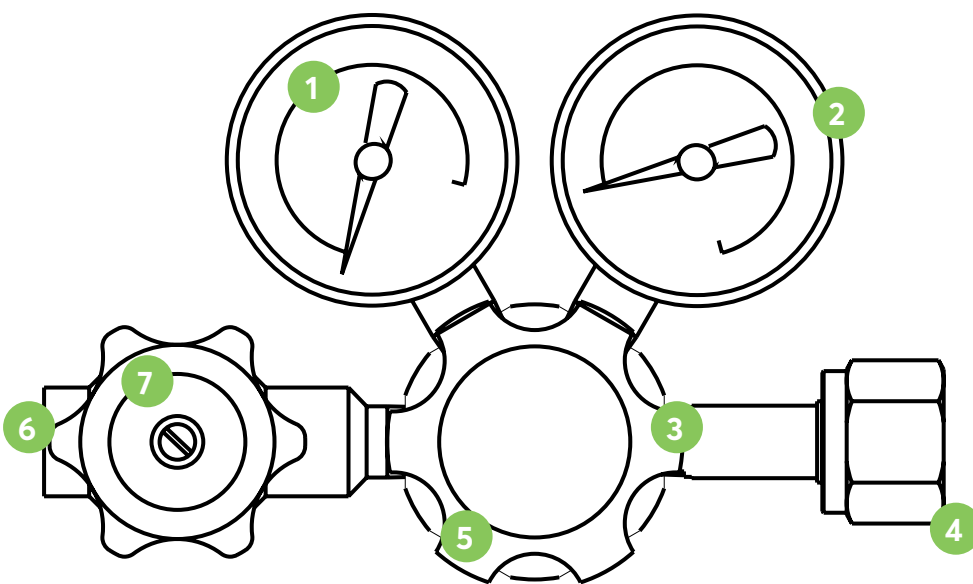

- 1 Delivery pressure gauge
- 2 Inlet pressure gauge
- 3 Regulator body
- 4 Inlet fitting to cylinder (CGA connection)
- 5 Pressure adjusting knob
- 6 Outlet port to process
- 7 Outlet valve, open/close

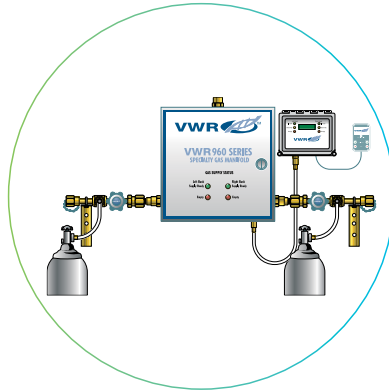
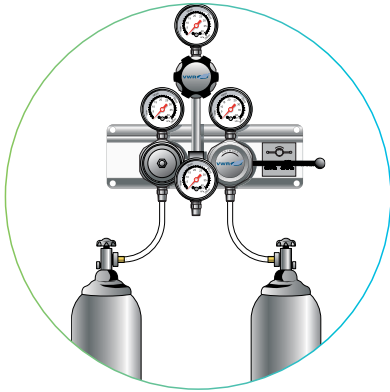

Proper selection is critical for a safe and effective transfer of the gas from the cylinder or pipeline to the instrument. Regulators are designed to control pressure and will not measure or control flow. An external device such as a flowmeter or metering valve specifically designed for flow control should be used for that purpose.

SELECTING THE CORRECT REGULATOR FOR YOUR NEEDS INVOLVES MANY VARIABLES THAT NEED TO BE CAREFULLY CONSIDERED.

– Materials compatibility

Materials used to construct the pressure regulator need to be compatible with the intended gas service. All the wetted areas (parts of the regulator in contact with the gas) must be selected to avoid any reaction with the gas that could cause contamination in the gas stream or deterioration of the regulator components. Refer to Gas Materials Compatibility table on page 15.

– Inlet pressure rating

Inlet pressure can range from low-pressure in pipeline usage, to high-pressure from compressed gas cylinders. The regulator may be for line use or cylinder use. Regulators for line use typically have just one gauge that indicates delivery pressure. However, a cylinder regulator has two gauges; one to show inlet pressure and the other to show delivery pressure. An exception to this would be the use of regulators for liquid gas cylinder. In this application only the delivery pressure gauge would be required since the supply pressure is generally constant. It's also critical to insure that the selected regulator is capable of

handling the incoming inlet pressure. When the gas is supplied from a cylinder, the CGA (Compressed Gas Association) inlet connection will dictate the maximum supply pressure, which can range from 200psi to over 6,000psi.

– Delivery pressure range

The desired working pressure range for any given application may range from low-pressure (0-15psi) to a much higher working pressure (6,000psi). The selected regulator must be able to supply the proper working pressure consistent with the requirements of the process.

– Gas purity

A regulator's ability to maintain gas purity level is a critical factor to consider. The selected regulator must be resistant to any introduction of contaminants that can be detrimental to the process. In addition to the proper selection of materials for gas compatibility, the design, assembly, and testing are also important factors. Cleanroom assembly and helium leak testing are common procedures used to insure regulator integrity.

– Pressure regulation, single-stage or two-stage design

All regulators are designed to reduce the inlet pressure to a desired working pressure. The regulator can reduce the pressure in either one step or two steps. A single-stage regulator reduces the pressure in one step, and a two-stage regulator reduces the pressure in two steps. Either may be suitable for the application based on the desired pressure control.

Selecting a single-stage or two-stage regulator

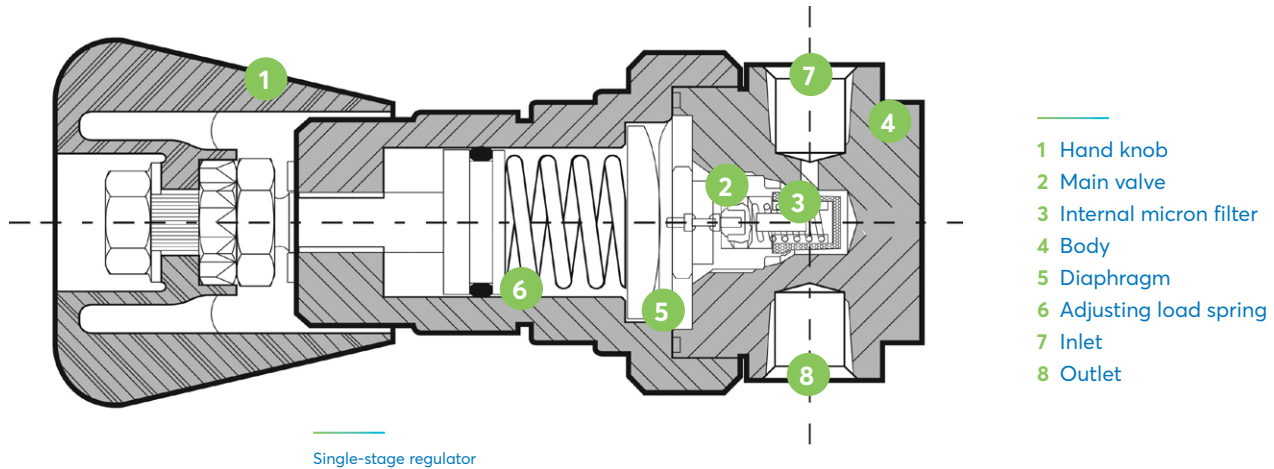

Single-stage regulators are best suited for applications in which:

- Manual periodic adjustment of the delivery pressure settings is not a problem, or
- The inlet pressure remains constant, such as the case in gas withdrawal from liquid cylinders.

Two-stage regulators are two regulators built into a single regulator body. The first regulator (first stage) is preset at a non-adjustable pressure to lower the incoming pressure. The second regulator (second stage) is adjustable within the desired delivery range. A two-stage regulator allows for steady delivery pressure without periodic adjustment, making it well suited for applications requiring constant pressure from full to nearly empty cylinder.

OPERATION OF PRESSURE REGULATORS

Single-stage regulators

Gas enters the inlet (high pressure) chamber and its pressure is indicated on the high pressure gauge. When the pressure-adjusting knob is turned counterclockwise and completely backed out to the stop, a valve and seat assembly located between the

inlet chamber and the delivery (low pressure) chamber prevent gas from moving any further. A filter located at the inlet to the valve and seat assembly removes particulate matter from the gas stream to help protect the seat area.

Turning the pressure-adjusting knob clockwise causes the adjusting screw to push against a spring button that compresses the pressure-adjusting spring. The force of the compressed spring, in turn, causes the diaphragm to flex and push against the valve. This opens the regulator, allowing gas to flow from the inlet chamber to the delivery chamber of the regulator.

Gas entering the delivery pressure chamber begins to build pressure and creates a counter-force (counter to the pressure adjusting spring) on the diaphragm. This pressure is indicated on the delivery pressure gauge attached to the regulator body. When pressure builds sufficiently to counteract the spring compression, it pushes the diaphragm away from the valve poppet – allowing the regulator valve to close. In this instance, delivery chamber pressure is controlled or regulated by the amount of spring compression placed on the diaphragm, and is selectable by turning the pressure-adjusting knob until desired pressure is indicated on the delivery pressure gauge.

When gas from the delivery pressure chamber is sent to the end process, the resulting decrease in gas volume in the delivery

chamber causes a pressure reduction in the chamber. When this occurs, the spring compression causes the diaphragm to push the valve open, allowing additional gas to enter the delivery chamber.

Two-stage regulators

These regulators incorporate all the components of a single-stage regulator, plus the addition of a second pressure-adjusting valve.

The first stage is not user-adjustable with the pressure-adjusting spring "pre-compressed" at the factory. This allows the first stage to feed pressure at approximately 250 to 350psig to the second (adjustable) stage. The inter-stage pressure will be higher when the desired pressure is higher.

The second stage then performs in a manner similar to that of a single-stage regulator, except that the inlet pressure to the second stage is relatively constant. The two-step pressure reduction produces a final delivery pressure that's effected by the changes in cylinder pressure.

PRESSURE	TO OBTAIN								
	atm	bar	ft of H ₂ O	in of hg	in of H ₂ O	kg/cm ²	kPa	mm of Hg	PSI
MULTIPLY BY									
atm	-	1.01325	33.932	29.921	407.1827	1.0332	101.3171	760	14.696
bar	0.98692	-	33.4883	29.53	401.8596	1.019716	100	750.062	14.50368
Ft. of H ₂ O	0.02947	0.029891	-	0.882646	12	0.03048	2.989	22.4198	0.433107
in of Hg	0.03342	0.033864	1.134	-	13.6	0.034532	3.376895	25.4	0.49115
in of H ₂ O	0.00246	0.002499	0.083333	0.073556	-	0.00254	0.0249089	1.86832	0.03609
kg/cm ²	0.9678	0.980665	32.8084	28.95903	393.7008	-	98.03922	735.5592	14.22334
kPa	0.00987	0.01	0.33456	0.29613	4.01472	0.0102	-	7.5006	0.14504
mm of Hg	0.00132	0.001333	0.044603	0.03937	0.53524	0.00136	0.133322	-	0.019337
PSI	0.06805	0.068948	2.3089	2.036	27.70851	0.070307	6.89465	51.175	-

FLOW	TO OBTAIN							
	cm ³ /min	cm ³ /sec	ft ³ /hr	ft ³ /min	m ³ /hr	m ³ /min	L/hr	Lpm
MULTIPLY BY								
cm ³ /min	-	0.0166667	0.0021189	0.0000353	0.00006	0.000001	0.06	0.001
cm ³ /sec	60	-	0.1271340	0.0021189	0.0036	0.00006	3.6	0.06
ft ³ /hr	471.9474	7.865790	-	0.0166667	0.0283168	0.0004719	28.31685	-
ft ³ /min	28,316.85	471.9474	60	-	1.699008	0.0283168	1699.008	-
m ³ /hr	16,666.67	277.7778	35.31467	0.5885777	-	0.0166667	1000	-
m ³ /min	1,000,000	16,666.67	2118.876	35.31467	60	-	60,000	1000

DENSITY	TO OBTAIN				
	gms/cm ³	kg/m ³	lbs/ft ³	lbs/in ³	lbs/U.S. gal
MULTIPLY BY					
gms/cm ³	-	1000	62.428	0.0361273	8.3454
kg/m ³	0.001	-	0.062428	3.61273 x 10 ⁻⁵	0.0083454
lbs/ft ³	0.0160185	16.018463	-	5.78704 x 10 ⁻⁴	0.13368
lbs/in ³	27.679905	27.679.9	1728	-	231
lbs/U.S. gal	0.1198264	119.8264	7.4805195	0.004329	-

VWR® HEAVY-DUTY SINGLE-STAGE GAS REGULATOR WITH NEOPRENE DIAPHRAM, BRASS

These heavy-duty regulators have a brass body that's suitable for a wide variety of applications where small changes in gas delivery pressure will not effect performance. Gauges are easy to read, and regulators are supplied with shut-off valves. Particulates are eliminated from gas stream with a ten micron sintered metal inlet filter.



NOTE: For noncorrosive gases only.

Gas	Inlet CGA	Flow Capacity, Standard CF	Delivery Range, psi	Delivery Pressure Gauge, psig	Supply Pressure Gauge, psig	Cat. No.
Acetylene	510	800	0-15	30	400	55850-200
Carbon Dioxide	320	1,700	0-50	60	4,000	55850-215
Carbon Dioxide	320	2,700	0-100	150	4,000	55850-220
Ar/He/N	580	5,640	0-50	60	4,000	55850-205
Ar/He/N	580	11,300	0-100	150	4,000	55850-210
Hydrogen	350	8,400	0-50	60	4,000	55850-225
Hydrogen	350	15,200	0-100	150	4,000	55850-230
Hydrogen	350	20,500	0-500	600	4,000	55850-275
Nitrogen	580	5,500	0-500	600	4,000	55850-277
Oxygen	540	1,900	0-50	60	4,000	55850-235
Oxygen	540	3,700	0-100	150	4,000	55850-240
Oxygen	540	5,100	0-500	600	4,000	55850-270
Propane*	510	500	0-50	60	400	55850-245
Nitrous Oxide	326	1,700	0-50	60	4,000	55850-250
Breathing Air	346	2,100	0-50	60	4,000	55850-255
Industrial Air	590	2,100	0-50	60	4,000	55850-260

*Can be used with any of the other welding-grade petroleum fuel gases.

SPECIFICATIONS

Body	Brass
Bonnet	Chrome-plated die cast
Seat	One-piece encapsulated seat design with an internal filter and a PTFE Teflon® seat

Diaphragm	Reinforced neoprene 2 $\frac{3}{4}$ "
Gauge	2"
Outlet	Needle valve with $\frac{1}{4}$ " male outlet thread - $\frac{1}{4}$ " hose barb also included
Max Inlet	3000 psig

Flow data

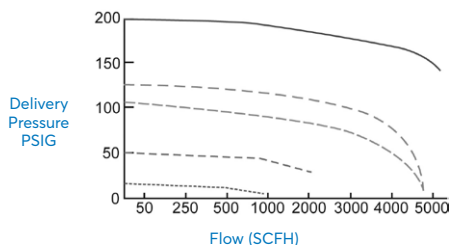
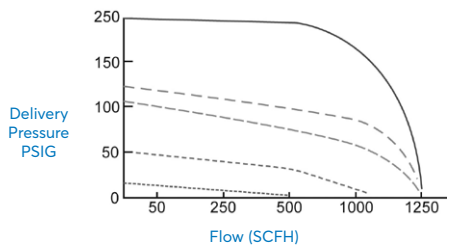

Dimensions

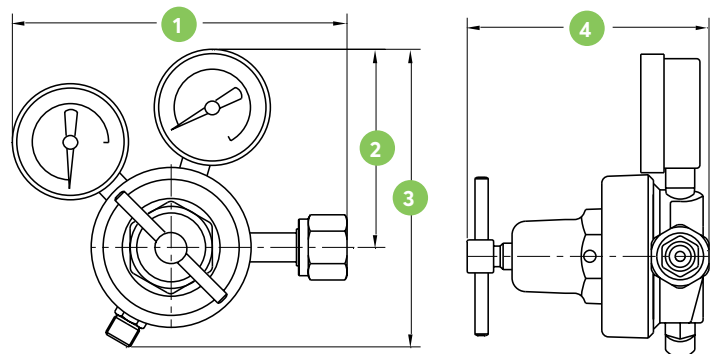

- 1 6.50"
- 2 3.83"
- 3 5.75"
- 4 4.75"

VWR® MULTISTAGE GAS REGULATORS WITH NEOPRENE DIAPHRAGMS, BRASS

These regulators are designed for applications where a constant working pressure is critical over a wide range of inlet pressures and flow rates. They feature safe, accurate, and sensitive pressure control. Solid forged brass body contains two regulators. First stage reduces full cylinder pressure. Second stage delivers a constant pressure to the regulator outlet. Particulates, tank scale, and rust are eliminated from gas stream with sintered inlet filter.



NOTE: For noncorrosive gases only.

Gas	Inlet CGA	Flow Capacity, Standard CF	Delivery Range, psi	Delivery Pressure Gauge, psig	Supply Pressure Gauge, psig	Cat. No.
Acetylene	510	1,100	0-15	30	500	55850-472
Arg/Nit/Hel	580	1,500	0-50	60	4,000	55850-474
Arg/Nit/Hel	580	3,200	0-100	200	4,000	55850-476
Arg/Nit/Hel	580	4,400	0-250	400	4,000	55850-478
Carbon Dioxide	320	1,800	0-50	60	4,000	55850-480
Carbon Dioxide	320	3,800	0-125	200	4,000	55850-482
Hydrogen	350	4,560	0-50	60	4,000	55850-484
Hydrogen	350	6,460	0-125	200	4,000	55850-486
Oxygen	540	1,140	0-50	60	4,000	55850-488
Oxygen	540	1,615	0-100	200	4,000	55850-490
Oxygen	540	2,185	0-250	400	4,000	55850-492
Nitrous Oxide	326	970	0-50	60	4,000	55850-494
Breathing Air	346	1,400	0-50	60	4,000	55850-496
Industrial Air	590	1,200	0-50	60	4,000	55850-498
Medical Oxygen	280	1,140	0-50	60	4,000	55850-388
Mix— Includes O ₂ and CO ₂ (less than 7%)	280	1,650	0-125	200	4,000	55850-390
Industrial Oxygen Mix	296	1,200	0-50	60	4,000	55850-392
Industrial Medical Oxygen	500	1,100	0-50	60	4,000	55850-396
Mix— Includes O ₂ and CO ₂ (greater than 7%)	500	1,600	0-125	200	4,000	55850-398

SPECIFICATIONS

Body	Brass
Bonnet	Die Cast
Seat	One-piece encapsulated seat with an internal filter and a PTFE Teflon® seat

Diaphragm	Neoprene 2 3/4"
Gauge	2"
Outlet	Needle Valve with 1/4" male outlet thread 1/4" Hose Barb also included
Max Inlet	3000 psig

Flow data

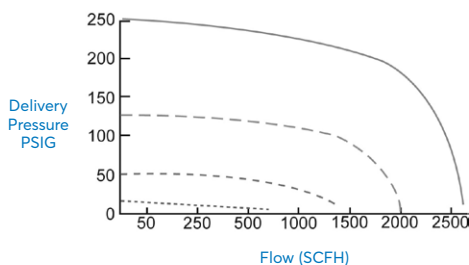
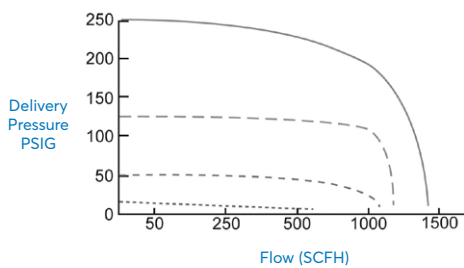

Dimensions

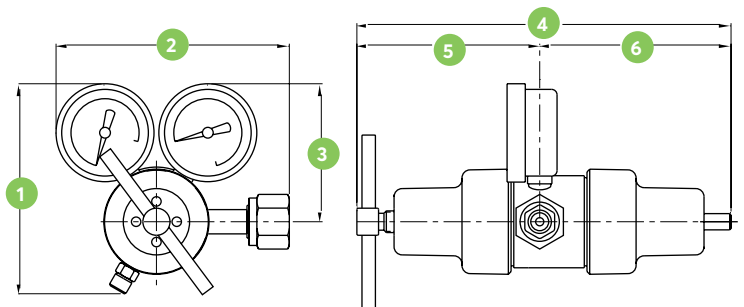

- 1 4.85"
- 2 5.38"
- 3 3.18"
- 4 8.63"
- 5 4.22"
- 6 4.41"

VWR® MULTISTAGE GAS REGULATORS WITH STAINLESS STEEL DIAPHRAGMS

Designed for gas chromatography applications where a constant working pressure is critical over a wide range of inlet pressures and flow rates. They feature safe, accurate, and sensitive pressure control. Solid forged brass body contains two regulators. First stage reduces full cylinder pressure, second stage delivers a constant pressure to the regulator outlet. Particulates, tank scale, and rust are eliminated from gas stream with sintered inlet filter.



Conforms to CGA E-4 self-seating internal relief valve

Gas	Inlet CGA	Flow Capacity, Standard CFH	Delivery Range, psi	Delivery Pressure Gauge, psig	Supply Pressure Gauge, psig	Cat. No.
Arg/Nit/Hel	580	255/305/1,350	0-15	30	4,000	55850-420
Arg/Nit/Hel	580	765/915/2,430	0-50	60	4,000	55850-422
Arg/Nit/Hel	580	1,445/1,730/4,590	0-125	200	4,000	55850-424
Carbon Dioxide	320	240	0-15	30	4,000	55850-412
Carbon Dioxide	320	730	0-50	60	4,000	55850-414
Carbon Dioxide	320	1,377	0-125	200	4,000	55850-416
Carbon Dioxide	320	1,863	0-250	400	4,000	55850-418
Hydrogen	350	1,140	0-15	30	4,000	55850-428
Hydrogen	350	3,420	0-50	60	4,000	55850-430
Hydrogen	350	6,460	0-125	200	4,000	55850-432
Hydrogen	350	8,740	0-250	400	4,000	55850-434
Oxygen	540	285	0-15	30	4,000	55850-436
Oxygen	540	855	0-50	60	4,000	55850-438
Oxygen	540	1,615	0-125	200	4,000	55850-440
Oxygen	540	2,185	0-250	400	4,000	55850-442
Industrial Oxygen Mix	296	300	0-15	30	4,000	55850-452
Industrial Oxygen Mix	296	1,700	0-125	200	4,000	55850-456
Industrial Oxygen Mix	296	2,300	0-250	400	4,000	55850-458
Medical Oxygen Mix—Includes O₂ and CO₂ (less than 7%)						
	280	285	0-15	30	4,000	55850-444
	280	855	0-50	60	4,000	55850-446
	280	2,185	0-250	400	4,000	55850-450
Medical Oxygen Mix— (Includes O₂ and CO₂ greater than 7%)						
	500	290	0-15	30	4,000	55850-460
	500	880	0-50	60	4,000	55850-462
	500	1,600	0-125	200	4,000	55850-464
	500	2,200	0-250	400	4,000	55850-468

SPECIFICATIONS

Body	Brass
Bonnet	Die Cast
Seat	One-piece encapsulated seat design with an internal filter and a PTFE Teflon® seat

Diaphragm	Stainless Steel
Gauge	2"
Outlet	Needle valve with 1/4" NPT male outlet thread 1/4" Hose barb also included

Flow data

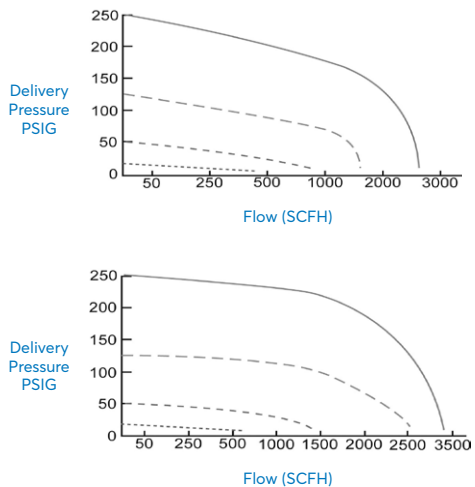

Dimensions

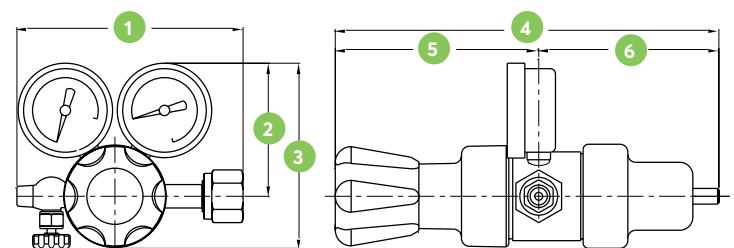

- 1 5.41"
- 2 3.18"
- 3 4.44"
- 4 9.18"
- 5 4.87"
- 6 4.31"

VWR® HIGH-PURITY SINGLE-STAGE GAS REGULATORS, BRASS

These high-purity regulators have a brass barstock body and are suitable for a variety of applications where slight pressure variations in delivery pressure can be tolerated, such as high-purity gas applications, research sample systems, process analyzers, gas chromatography, EPA protocol mixes, laser gas systems, and emission monitoring systems. A stainless steel diaphragm eliminates contamination from diffusion or out-gassing. A one-piece PTFE encapsulated seat design includes a sintered filter to protect the seat from particulate contamination. The 1x10⁻⁹cc/sec. inboard helium leak rate maintains gas purity levels.



Front or back panel mountable

Gas	Inlet CGA	Flow Capacity, Standard CFH	Delivery Pressure, psig	Cat. No.
Arg/Nit/Hel	580	1,020/1,220/3,200	1-50	55850-600
Arg/Nit/Hel	580	2,500/3,000/8,000	1-125	55850-602
Carbon Dioxide	320	970	1-50	55850-604
Carbon Dioxide	320	2,400	1-125	55850-606
Hydrogen	350	4,500	1-50	55850-608
Hydrogen	350	11,430	1-125	55850-610
Oxygen	540	1,100	1-50	55850-612
Oxygen	540	2,800	1-125	55850-614
Nitrous Oxide	326	970	1-50	55850-616
Industrial Air	590	1,200	1-50	55850-618
Breathing Air	346	1,200	1-50	55850-620

SPECIFICATIONS

Body	Brass Barstock
Bonnet	Brass Barstock
Seat	PTFE Teflon®
Diaphragm	Type 316L Stainless Steel
Gauge	2"
Outlet	Diaphragm Valve with ¼ Tube Fitting (Swagelok®)
Max Inlet	3000 psig

Flow data

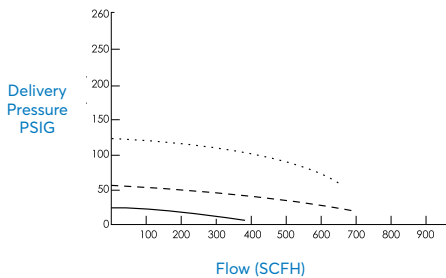

15 @ 200 PSIG INLET ———
 50 @ 200 PSIG INLET - - - -
 125 @ 200 PSIG INLET ······

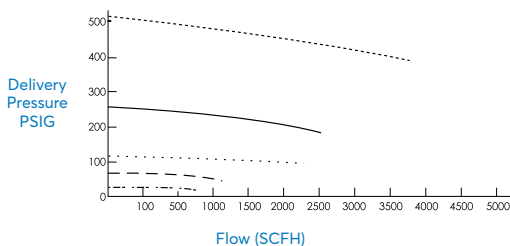

15 @ 2000 PSIG INLET ······
 50 @ 2000 PSIG INLET - - - -
 125 @ 2000 PSIG INLET ······
 250 @ 2000 PSIG INLET ———
 500 @ 2000 PSIG INLET - - - -

Diagram & dimensions

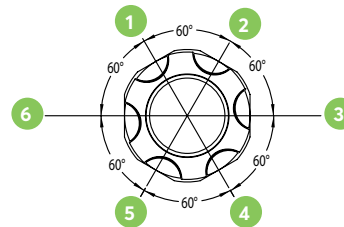

- 1 Outlet gauge port
- 2 Inlet gauge port
- 3 Inlet port
- 4 Aux. high pressure port
- 5 Aux. low pressure port
- 6 Outlet port

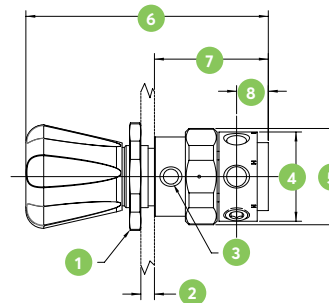

- 1 Panel nut
- 2 Panel ref. 3/8" thick max. Panel cut-out 1.39"
- 3 1/8" NPT vent port
- 4 1.97"
- 5 2.13"
- 6 5.63"
- 7 2.48"
- 8 0.71"

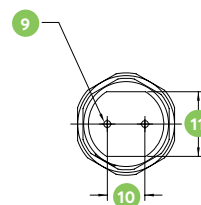

VWR® HIGH-PURITY TWO-STAGE GAS REGULATORS, BRASS

These high-purity two-stage regulators have a brass barstock body and are suitable for high-purity applications, research sample systems, process analyzers, gas analyzers, gas chromatography, EPA protocol mixes, laser gas systems, and emission monitoring systems. The two-stage design provides constant outlet pressure regardless of change in cylinder pressure. A stainless steel diaphragm eliminates contamination from diffusion or out-gassing. A one-piece PTFE encapsulated seat design includes a sintered filter to protect the seat from particulate contamination. The 1×10^{-9} cc/sec. inboard helium leak rate maintains gas purity levels.



Front panel mountable

Gas	Inlet CGA	Flow Capacity, Standard CFH	Delivery Pressure, psig	Cat. No.
Arg/Nit/Hel	580	1,020/1,220/3,200	1-50	55850-622
Arg/Nit/Hel	580	1,020/1,220/3,200	1-125	55850-624
Carbon Dioxide	320	970	1-50	55850-626
Carbon Dioxide	320	970	1-125	55850-628
Hydrogen	350	4,500	1-50	55850-630
Hydrogen	350	4,500	1-125	55850-632
Oxygen	540	1,100	1-50	55850-634
Oxygen	540	1,100	1-125	55850-636
Nitrous Oxide	326	970	1-50	55850-638
Industrial Air	590	1,200	1-50	55850-640
Breathing Air	346	1,200	1-50	55850-642

SPECIFICATIONS

Body	Brass Barstock
Bonnet	Brass Barstock
Seat	PTFE Teflon®
Diaphragm	Type 316L Stainless Steel
Gauge	2"
Outlet	Diaphragm Valve with 1/4 Tube Fitting (Swagelok)
Max Inlet	3000 psig

Flow data

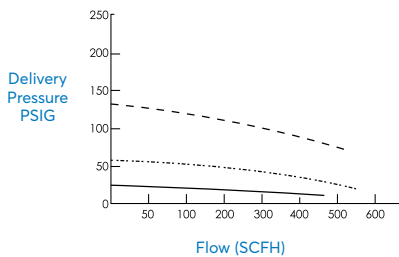

15 @ 200 PSIG INLET ———
 50 @ 200 PSIG INLET ·····
 125 @ 200 PSIG INLET - - -

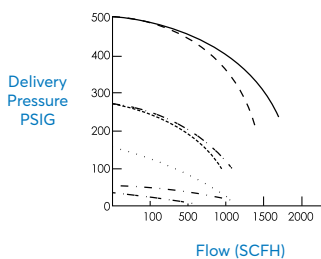

15 @ 2000 PSIG INLET ·····
 50 @ 2000 PSIG INLET - - -
 125 @ 2000 PSIG INLET · · · · ·
 250 @ 350 PSIG INLET ·····
 250 @ 2000 PSIG INLET - - -
 500 @ 600 PSIG INLET · · · · ·
 500 @ 2000 PSIG INLET ———

Diagram & dimensions

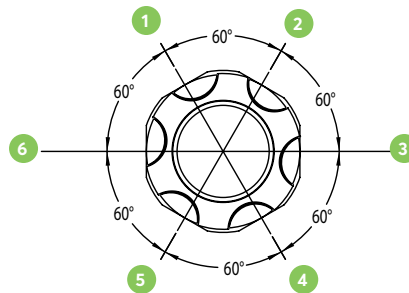

- 1 Outlet gauge port
- 2 Inlet gauge port
- 3 Inlet port
- 4 Intermediate port
- 5 Aux. low pressure port
- 6 Outlet port

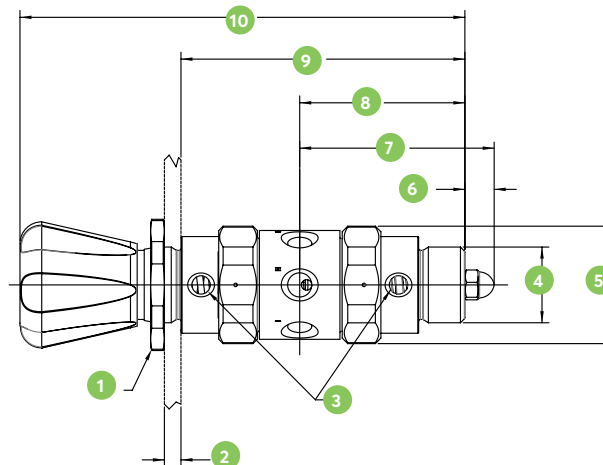

- 1 Panel nut
- 2 Panel ref. 3/8" thick max. Panel cut-out 1.39"
- 3 1/8" FNPT vent
- 4 1.37"
- 5 2.13"
- 6 0.53"
- 7 3.52"
- 8 3.00"
- 9 5.14"
- 10 8.20"

VWR® HIGH-PURITY SINGLE-STAGE REGULATORS, STAINLESS STEEL

These stainless steel barstock body regulators are suitable for a variety of applications where slight pressure variations in delivery pressure can be tolerated. They may be used in corrosive gas applications. They are also ideal for high-purity gas applications, research sample systems, process analyzers, gas chromatography, EPA protocol mixes, laser gas systems, and emission monitoring systems. A stainless steel diaphragm eliminates contamination from diffusion or out-gassing. A one-piece PTFE encapsulated seal design includes a sintered filter to protect the seat from particulate contamination. The 1×10^{-9} cc/sec. inboard helium leak test rate maintains gas purity levels.



Front or back panel mountable

Gas	Inlet CGA	Flow Capacity, Standard CFH	Delivery Pressure, psig	Cat. No.
Arg/Nit/Hel	580	1,020/1,220/3,200	1-50	55850-650
Arg/Nit/Hel	580	2,500/3,000/8,000	1-125	55850-652
Carbon Dioxide	320	970	1-50	55850-654
Carbon Dioxide	320	2,400	1-125	55850-656
Hydrogen	350	4,500	1-50	55850-658
Hydrogen	350	11,430	1-125	55850-660
Oxygen	540	1,100	1-50	55850-662
Oxygen	540	2,800	1-125	55850-664
Corrosive	330	700-1,000	1-50	55850-666
Corrosive	330	1,900-2,700	1-125	55850-668
Corrosive	660	700-1,000	1-50	55850-670

SPECIFICATIONS

Body	316L Stainless Steel Barstock
Bonnet	Chrome Plated Brass Barstock
Seat	PTFE Teflon®
Diaphragm	316L Stainless Steel
Gauge	2"
Outlet	Stainless Diaphragm Valve with 1/4" Tube Fitting (Swagelok)
Max Inlet	3000 psig

Flow data

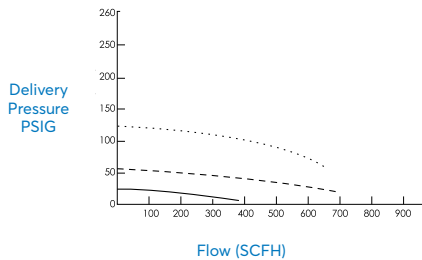

15 @ 200 PSIG INLET ———
 50 @ 200 PSIG INLET - - - - -
 125 @ 200 PSIG INLET ·····

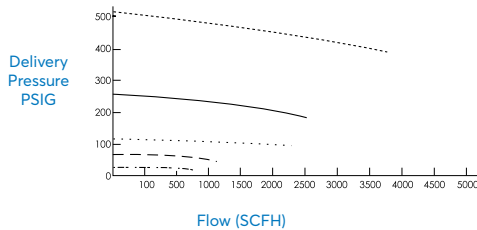

15 @ 2000 PSIG INLET ·····
 50 @ 2000 PSIG INLET - - - - -
 125 @ 2000 PSIG INLET - · - · -
 250 @ 2000 PSIG INLET ———
 500 @ 2000 PSIG INLET - - - - -

Diagram & dimensions

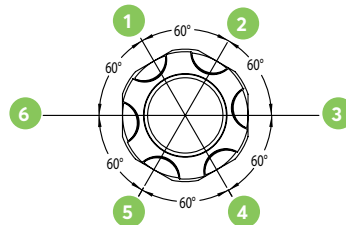

- 1 Outlet gauge port
- 2 Inlet gauge port
- 3 Inlet port
- 4 Aux. high pressure port
- 5 Aux. low pressure port
- 6 Outlet port

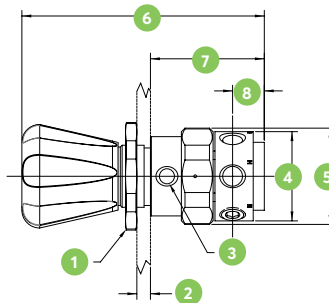

- 1 Panel nut
- 2 Panel ref. 3/8" thick max.
Panel cut-out 1.39"
- 3 1/8" NPT vent port
- 4 1.97"
- 5 2.13"
- 6 5.63"
- 7 2.48"
- 8 0.71"
- 9 10 - 32 UNF thread (typical)
- 10 0.875"
- 11 1.50"

VWR® HIGH-PURITY TWO-STAGE GAS REGULATORS, STAINLESS STEEL

Regulators have a stainless steel barstock body and are suitable for corrosive gas applications, high-purity gas applications, research sample systems, process analyzers, gas chromatography, EPA protocol mixes, laser gas systems, and emission monitoring systems. The two-stage design provides constant outlet pressure regardless of change in cylinder pressure. They may be used with corrosive gas applications. A stainless steel diaphragm eliminates contamination from diffusion or out-gassing. A one-piece PTFE encapsulated seat design includes a sintered filter to protect the seat from particulate contamination. The 1×10^{-9} cc/sec. inboard helium leak rate maintains gas purity levels.



Front panel mountable

Gas	Inlet CGA	Flow Capacity, Standard CFH	Delivery Pressure, psig	Cat. No.
Arg/Nit/Hel	580	1020/1220/3200	1-50	55850-674
Arg/Nit/Hel	580	1020/1220/3200	1-125	55850-676
Carbon Dioxide	320	970	1-50	55850-678
Carbon Dioxide	320	970	1-125	55850-680
Hydrogen	350	4500	1-50	55850-682
Hydrogen	350	4500	1-125	55850-684
Oxygen	540	1100	1-50	55850-686
Oxygen	540	1100	1-125	55850-688
Corrosive	330	700-1000	1-50	55850-690
Corrosive	330	700-1000	1-125	55850-692
Corrosive	660	700-1000	1-50	55850-694

SPECIFICATIONS

Body	316L Stainless Steel Barstock
Bonnet	Chrome Plated Brass Barstock
Seat	PTFE Teflon®
Diaphragm	316L Stainless Steel
Gauge	2"
Outlet	Stainless Diaphragm Valve with 1/4" Tube Fitting (Swagelok)
Max Inlet	3000 psig

Flow data

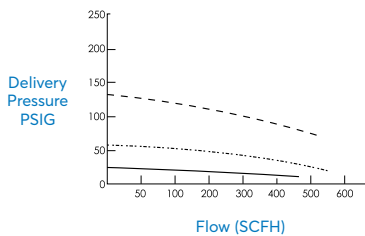

15 @ 200 PSIG INLET ———
 50 @ 200 PSIG INLET - - - - -
 125 @ 200 PSIG INLET - - - - -

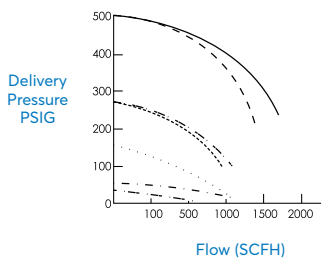

15 @ 2000 PSIG INLET - - - - -
 50 @ 2000 PSIG INLET - - - - -
 125 @ 2000 PSIG INLET - - - - -
 250 @ 350 PSIG INLET - - - - -
 250 @ 2000 PSIG INLET - - - - -
 500 @ 600 PSIG INLET - - - - -
 500 @ 2000 PSIG INLET - - - - -

Diagram & dimensions

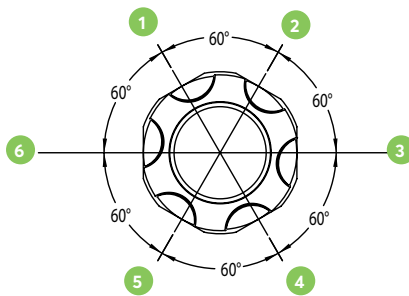

- 1 Outlet gauge port
- 2 Inlet gauge port
- 3 Inlet port
- 4 Intermediate port
- 5 Aux. low pressure port
- 6 Outlet port

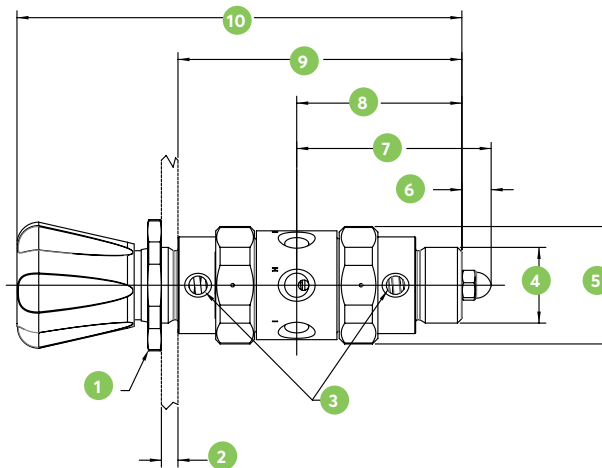

- 1 Panel nut
- 2 Panel ref. 3/8" thick max. Panel cut-out 1.39"
- 3 1/8" FNPT vent
- 4 1.37"
- 5 2.13"
- 6 0.53"
- 7 3.52"
- 8 3.00"
- 9 5.14"
- 10 8.20"

Gas regulator accessories



OUTLET HOSE BARBS

Description	Cat. No.	Unit
Brass, 6.4 mm (1/4") NPTM to 6.4 mm (1/4") Hose Barb	82023-810	Each
Brass, 6.4 mm (1/4") NPTM to 3.2 mm (1/8") Hose Barb	82023-812	Each
Brass, 6.4 mm (1/4") NPTF to 6.4 mm (1/4") Hose Barb	82023-814	Each



OUTLET HOSE BARBS

Description	Cat. No.	Unit
Brass, 6.4 mm (1/4") NPTM to 6.4 mm (1/4") Tube Fitting	82023-816	Each
Brass, 6.4 mm (1/4") NPTM to 3.2 mm (1/8") Tube Fitting	82023-818	Each
Stainless Steel, 6.4 mm (1/4") NPTM to 3.2 mm (1/8") Tube Fitting	82023-822	Each

GASKETS

Description	Cat. No.	Unit
CO ₂ Gasket Inlet, 19 mm (3/4") Dia.	82023-825	Pack of 25



OUTLET NEEDLE VALVES

These valves are used where a shut off feature or some degree of throttling is required.

SPECIFICATIONS

Inlet/Outlet	1/4 MNPT
Inlet Pressure	3000 psig
Packing Material	PTFE
Body Material	Brass

Description	Cat. No.	Unit
Brass, 6.4 mm (1/4") NPTM to 6.4 mm (1/4") NPTM	82023-798	Each
Chrome Plated, 6.4 mm (1/4") NPTM to 6.4 mm (1/4") NPTM	82023-802	Each



OUTLET DIAPHRAGM VALVES

These valves are used in high-purity systems where gas leakage and in-board diffusion of air or moisture must be kept to a minimum.

The packless design has an in-board helium leak rate of 1×10^{-9} cc/sec.

SPECIFICATIONS

Inlet	1/4 MNPT or 1/4 FNPT
Outlet	1/4 FNPT
Max. Inlet Pressure	3500 psig
Seat Material	PCTFE (Kel-FTM)

Description	Cat. No.	Unit
Brass, 6.4 mm (1/4") NPTM to 6.4 mm (1/4") NPTF	82023-804	Each
Chrome Plated, 6.4 mm (1/4") NPTM to 6.4 mm (1/4") NPTM	82023-806	Each
Stainless Steel, 6.4 mm (1/4") NPTM to 6.4 mm (1/4") NPTM	82023-808	Each

Gas delivery systems



When specialty gases are used in significant volumes, a centralized gas delivery system is a practical necessity. A well-conceived delivery system will reduce operating costs, increase productivity, and enhance safety.

A centralized system will allow the consolidation of all cylinders into one storage location. With all the cylinders in one place, inventory control will be streamlined and cylinder handling will be simplified and improved. Gases can be separated by type to enhance safety.

The frequency of cylinder change-outs is reduced in a centralized system. This is achieved by connecting multiple cylinders to manifolds in banks in such a way that one bank can be safely vented, replenished, and purged, while a second bank provides continuous gas service. Such a manifold system can supply gas to multiple instruments and even entire laboratories, eliminating the need for separate cylinders and/or regulators for each instrument.

Since cylinder switchover can be accomplished automatically by the manifold, cylinders in a bank will be uniformly exhausted, resulting in improved gas utilization and lower costs. Further, the integrity of the delivery system will be better protected since cylinder change-outs will be done in an isolated, controlled environment. The gas manifolds used in these systems should be equipped with check valves to prevent gas back-flow and purge assemblies to eliminate contaminants from the system during change-out. In addition, most gas delivery systems can

be configured with alarms to indicate when a cylinder or bank of cylinders needs replacing.

PURITY

The level of gas purity required at end-use point is extremely important in designing a gas delivery system. Maintaining this gas purity is simplified with a centralized system as previously described. Selection of materials of construction should be consistent throughout (please see the Gas Compatibility Guide on page 15). For example, if a research grade gas is being utilized, all stainless steel construction and diaphragm pack-less shut-off valves should be used to eliminate contamination of the gas stream.

In general, three levels of purity are sufficient to describe nearly any application.

The first level, usually described as a multi-purpose application, has the least stringent purity requirement. Typical applications are AA, ICP, and general gas chromatography. Manifolds for multi-purpose applications are economically designed for safety and convenience. Acceptable materials of construction include brass, copper, Teflon®, Tefzel® and Viton®. Packed valves such as needle valves and ball valves are often used for flow shutoff. Gas distribution systems manufactured to this level should not be used with high-purity or ultra-high purity gases.

The second level, called high-purity, requires a higher level of protection against contamination. Applications include gas chromatography where capillary columns are used and system integrity is important. Construction materials are similar to multi-purpose manifolds, except that flow shut-off valves are diaphragm pack-less to prevent diffusion of contaminants into the gas stream.

The third level is referred to as ultra-high purity. This level requires the highest level of purity for components in a gas delivery system. Trace measurement in gas chromatography is an example of an ultra-high purity application. Wetted materials for manifolds at this level must be selected to minimize trace components adsorption. These materials include 316 Stainless Steel, Teflon®, Tefzel®, and Viton®. All tubing should be 316SS cleaned and passivated. Flow shut-off valves must be diaphragm pack-less.

It is particularly important to recognize that components that are suitable for multi-purpose applications may adversely affect results in high or ultra-high purity applications. For example, out-gassing from neoprene diaphragms in regulators can cause excessive baseline drift and unresolved peaks.

TYPES OF GAS DELIVERY SYSTEMS

Single-Station Systems - In some applications, a gas is used only to calibrate instrumentation. For example, a continuous emissions monitoring system (CEMS) may only require calibration gases to flow for a few minutes each day. Such an application clearly does not require a large-scale automatic changeover manifold. However, the delivery system should be designed to protect against contamination of the calibration gas and to minimize costs and problems associated with cylinder change outs.

A single station manifold with bracket is an ideal solution for this type of application. It provides a safe and cost-effective means of connecting and changing out cylinders by eliminating the need to struggle with the regulator. When the calibration gas includes corrosive components such as HCl or NO, a purge assembly

should be incorporated into the manifold to allow the regulator to be purged with an inert gas (usually nitrogen) to protect it from corrosion. The single-station manifold can also be equipped with a second pigtail. This arrangement allows an additional cylinder to be connected or held in reserve. Switchover is accomplished manually using the cylinder shut off valves. This configuration is usually desirable with calibration gases since the precise mix of components generally varies somewhat from cylinder to cylinder, and a cylinder change may require resetting the instrument.

Semi-Automatic Switchover Systems - Many applications require larger volumes of gases beyond what is practical for a single-station manifold. Any pause in the gas supply results in lost or ruined experiments, a loss of productivity, and even downtime for an entire laboratory. Semi-automatic switchover systems provide the capability to switch from a primary to a reserve cylinder or bank without interrupting the gas supply – minimizing costly downtime. Once the primary cylinder or bank is depleted, the system automatically switches to the reserve cylinder or bank for continuous gas flow. The user then changes the empty cylinders out for new cylinders while the gas is still flowing from the reserve side. A bi-directional valve is used to indicate the primary or reserve side upon cylinder change-out.

Fully Automatic Programmable Switchover Systems – In some critical manufacturing and laboratory processes, an uninterrupted gas supply is an absolute necessity. Failure of the gas supply in these cases could result in loss of an entire lab's in-process experiments or even shutdown of a production line. The potential cost of either of these events is so high that the installation of a gas delivery system designed to provide an uninterrupted gas supply is clearly justified. A fully automatic programmable switchover system is generally selected for these applications.

These systems perform similar to the semi-automatic systems, but offer added features such as programmable switchover between the primary and reserve banks, automatic leak detection, and telemetry options for remote sensing and gas level detection.

Switchover Method			Standard PSIG Delivery		Gas Compatibility				
Pressure Differential	Manual	Fully Automatic	Pressure Ranges		Inert	Oxy	Fuel Gas	Corrosive Gases	Liquid Cyl.
N/A	N/A	N/A	0-15 to 0-500		X	X	X	X	X
X	N/A	N/A	0-15 to 0-125		X	X	X	X	X
X	N/A	N/A	0-15 to 0-125		X	X	N/A	X	X
N/A	N/A	X	30-100 to 50-200		X	X	X	N/A	X
N/A	N/A	X	30-100 to 50-200		X	X	N/A	N/A	X
N/A	N/A	X	0-225		X	X	N/A	N/A	X
N/A	N/A	X	0-225		X	X	X	X	X
X	N/A	N/A	0-4500		X	N/A	X	N/A	N/A
N/A	X	N/A	0-4500		X	N/A	X	N/A	N/A

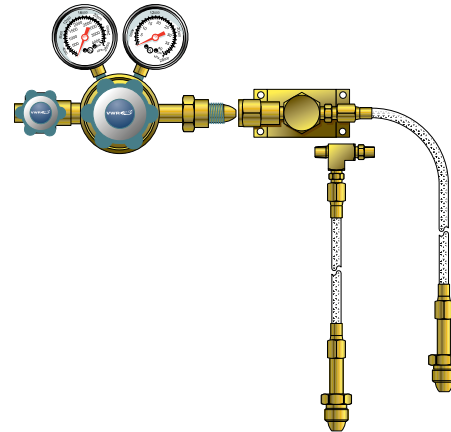
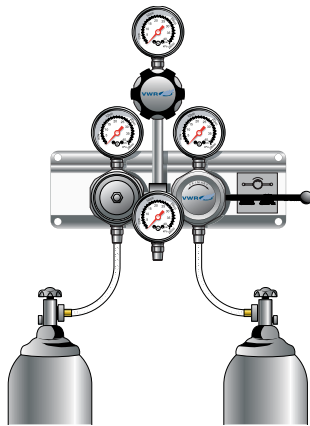

VWR® SG-900 SEMIAUTOMATIC SWITCHOVER MANIFOLD FOR NONCORROSIVE GASES

These semiautomatic switchover manifolds are designed to prevent gas from running out during testing and also to prevent downtime while changing out empty cylinders. The manifold will automatically switch gas supply from the Primary Cylinder (right side) to the Reserve Cylinder when the gas in the Primary Side is depleted. This will happen when the pressure on the Primary Gauge drops down to approximately 160psi. When changing an empty cylinder to a new one, the black lever must be turned over to the left side, making it now the Primary use side. The process is repeated when the left side gauge drops down to approximately 160psi. This manifold is available in chrome plated brass and stainless steel for corrosive gases. All the pigtails have a reverse flow check valve installed to prevent back flow of gases while changing cylinders. The outlet fitting on the delivery regulator is 1/4" NPT female pipe.

- Wall mounting panel
- Maximum inlet pressure 3000 psig
- Switchover pressure
- Ideal for CO₂ incubators
- Includes delivery pressure regulator
- All systems include stainless steel pigtails with a stainless steel inner core

Gas	Delivery Pressure Gauge, psi	Inlet CGA	Cat. No.
Argon, Nitrogen, Helium	0-125	580	82023-750
Argon, Nitrogen, Helium	0-15	580	82023-746
Argon, Nitrogen, Helium	0-50	580	82023-748
Breathing Air	0-125	346	55850-706
Carbon Dioxide	0-15	320	82023-734
Carbon Dioxide	0-125	320	82023-738
Carbon Dioxide	0-50	320	82023-736
Hydrogen	0-125	350	55850-708
Oxygen	0-50	540	82023-742
Oxygen	0-125	540	82023-744

Semi-automatic manifold, chrome-plated brass.
Includes delivery pressure regulator and pigtails.

VWR® REGULATOR WALL MOUNTS FOR HIGH-PURITY NONCORROSIVE AND CORROSIVE GASES

These manifolds are for use with cylinders with a maximum inlet of 3,000psig. They may be used with single- and two-stage general purpose, high-purity brass, high-purity stainless steel pressure regulators, and two-stage analytical pressure regulators. One-cylinder systems include one 36" pigtail; two-cylinder systems include two 36" pigtails. Regulators must be purchased separately.

- Wall bracket included
- Maximum inlet pressure 3,000 psig
- Includes 36" stainless steel lined stainless steel pigtail

SPECIFICATIONS

Pigtails	36" Stainless steel corrugated bellows
Bracket	304 Stainless steel
Fittings	Brass or 316 stainless steel

Gas	Inlet CGA	Includes	Cat. No.
Brass Protocol Stations for One Cylinder*			
Argon, Nitrogen, Helium	580	Brass Wall Bracket, 1 Pigtail	82023-704
Carbon Dioxide	320	Brass Wall Bracket, 1 Pigtail	82023-694
Oxygen	540	Brass Wall Bracket, 1 Pigtail	82023-702
Brass Protocol Stations for Two Cylinders*			
Argon, Nitrogen, Helium	580	Brass Wall Bracket, 2 Pigtails	82023-718
Carbon Dioxide	320	Brass Wall Bracket, 2 Pigtails	82023-708
Stainless Steel Protocol Stations for One Cylinder*			
Argon, Nitrogen, Helium	580	Stainless Steel Wall Bracket, 1 Pigtail	82023-722

*Order regulators separately

VWR® GAS CYLINDER WALL BRACKETS AND SUPPORTS

Each features all-steel construction and edges that are protected with steel-reinforced vinyl edge guarding to maintain and protect your cylinders and provide extra grip. Steel parts are sealed with epoxy powder paint to assure long service life and chemical resistance. Straps and cinch style buckles are chosen as primary means of support as they enable the cylinders to be held tight and secure against the brackets. Support straps are 1½ x 54" long polypropylene with steel cinch buckle and rate a robust 1,200psig strength. Supports hold cylinders from 4 to 12" diameter.

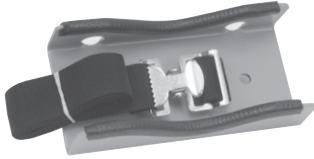

Mounting hole size: 10 mm (3/8 in.)



SINGLE CYLINDER WALL BRACKET

Description	Dimensions, W x D x H, cm (in.)	Cat. No.
Single Cylinder Wall Bracket	20.3 x 5.7 x 10.8 (8 x 2¼ x 4¼)	82023-826

SINGLE CYLINDER ADJUSTABLE BRACKET

Molded from reinforced polypropylene, this can be adjusted to snugly support any cylinder from 4 to 14" diameter. Unit is first set to designated cylinder diameter with recessed set screws locking in width position. Permanently mounts to wall using fasteners. Fastener type depends on mounting surface (fasteners supplied by customer). Strap and security chain sets included.

Description	Dimensions, W x D x H, cm (in.)	Cat. No.
Single Cylinder Adjustable Wall Bracket	22.9 x 10.2 x 12.7 (9 x 4 x 5)	82023-832

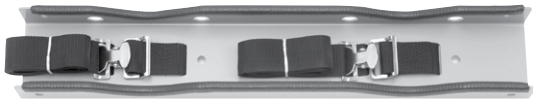

Mounting hole size: 10 mm (3/8 in.)

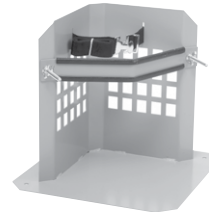

DOUBLE CYLINDER ADJUSTABLE BRACKET

Description	Dimensions, W x D x H, cm (in.)	Cat. No.
Double Cylinder Wall Bracket	61 x 5.1 x 10.2 (24 x 2 x 4)	82023-828

SINGLE CYLINDER FLOOR STAND

This stand safely supports 4 to 10in. diameter cylinders using a combination of cinch buckle, polypropylene strap, and 10-gauge steel bar. Designed and built for the safe storage of industrial and commercial use gas cylinders, this stationary rack is constructed from cold rolled steel. One cylinder-capacity stands share the 1½" polypropylene straps and steel cinch buckles used with the brackets. All welded construction and quality epoxy powder paint finishes provide structural integrity and long service life. As with the cylinder brackets, surfaces coming into direct contact with the cylinders are protected with steel-reinforced vinyl edge guards – protecting your equipment.



Mounting hole size: 10 mm (3/8 in.)

TRIPLE CYLINDER ADJUSTABLE BRACKET

Description	Dimensions, W x D x H, cm (in.)	Cat. No.
Triple Cylinder Wall Bracket	91.4 x 5.7 x 10.8 (36 x 2¼ x 4¼)	82023-830

Description	Dimensions, W x D x H, cm (in.)	Cat. No.
Single Cylinder Floor Stand	40.6 x 40.6 x 38.1 (16 x 16 x 15)	82023-836

Single stage and multistage regulators

VISIT
VWR.COM

For the complete product offering and more information.



VWR® GENERAL PURPOSE SINGLE-STAGE GAS REGULATORS

Cat. No. **55850-200** for Acetylene AA/FID/ICP; and Cat. No. **55850-260** for Air ICP.

Many additional options are available; visit vwr.com for a complete selection.



VWR® HIGH-PURITY SINGLE-STAGE GAS REGULATORS, BRASS

Search Cat. No. Series **55850-600** for a complete selection.

Ideal for calibration gases.



VWR® HIGH-PURITY SINGLE-STAGE REGULATORS, STAINLESS STEEL

Search Cat. No. Series **55850-652** for a complete selection.

Used for ultra high-purity/ corrosive gases.



VWR® GENERAL PURPOSE MULTISTAGE GAS REGULATORS

Search Cat. No. Series **55850-420** for a complete selection.

Delivers constant delivery pressure – no fluctuation.



VWR® MULTISTAGE GAS REGULATORS

Cat. No. **55850-414** is recommended for CO₂ incubators.

Many additional options available, shop vwr.com.



HIGH PURITY TWO-STAGE GAS REGULATORS FOR GC/MS

Cat. No. **55850-624** for Helium/Nitrogen; Cat. No. **55850-632** for Hydrogen; Cat. No. **55850-642** for Zero Air

Many additional options available, shop vwr.com.



VWR® HIGH-PURITY TWO STAGE GAS REGULATORS, STAINLESS STEEL

Search Cat. No. **55850-676** for a complete selection.

Ideal for ultra high-purity (6.0) or corrosive gases.

Setting science in motion to create a better world

At Avantor®, a new era has begun. From breakthrough discovery to agile delivery of advanced products and services across the globe, Avantor manufactures and distributes high-quality products, services and solutions to professionals in the life sciences and advanced technologies industries.



VWR, part of Avantor provides an integrated, seamless purchasing experience optimized for your success.

Learn how the new Avantor is moving forward at www.settingscienceinmotion.com

